

- A) (6) 1/2" MOUNTING HOLES ON CENTER
- B) SERVICE SWITCH ELECTRICAL CONNECTION POINT
- C) 14"x16" CONTROL PANEL
- D) 3/8" ALL-THREAD HANGING ROD
- E) 6" FLUE VENT PIPE
- F) 3/4" INLET GAS CONNECTION
- NOTE-UNIT HEATER FLUE AND GAS CONNECTION WILL VARY WITH UNIT HEATER SIZE AND MFG (SEE ATTACHED SUBMITTAL)
- 850 LBS

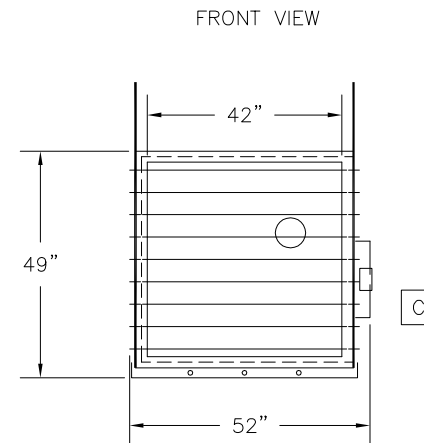

QTY	UNIT MODEL	1/FAN	HP	AMPS	CFM	SONES	TRANS	VOLTS	F/DISC
1	ER-142-400	115/1	3/4	14	16,500	12.6	5 KVA	460/1	YES

QTY	U/MODEL	VOLTS	AMPS	BTU/INPUT	BTU/OUTPUT	FLUE	GAS/CON	G/PRE
1	LF 400	115/1	5	390,000	312,000	6"	3/4"	6"